

- High Efficiency (over 90%)
- Up to 30A Output Current
- Standard Inputs of 24V and 48V
- Standard Outputs from 1.5V to 28V
- Microprocessor Controlled
- Isolated Input, Output & Baseplate
- Industry Standard Pin-Out
- Cover and Heatsink Optional
- Fixed Switching Frequency



DESCRIPTION

Series QED is Powercube's second-generation DC/DC converter product family. These converters are board-mountable and pin-compatible with industry standard products, yet offer superior efficiency and capability.

Low-loss power conversion is achieved by utilizing advances in synchronous rectification and integrated planar magnetic technology. Internal control functions performed by a microprocessor enable consistent performance, accuracy and effectiveness when responding to fault conditions. Advanced circuit design, reduced power loss, and single board construction make Series QED DC/DC converters highly reliable.

ADDITIONAL FEATURES

- Wide Input Voltage Range (36–75VDC for 48V, 18–36VDC for 24V)
- Input Under- and Over-Voltage Lockout
- Precisely-Regulated Output Voltage
- Adjustable Output Voltage Using "Trim Pin" (-20% to +10%)
- Low Output Ripple
- Overload, Short Circuit & Over-Voltage Protection, Thermal Shutdown (Auto recovery)
- Shutdown Control (Positive and Negative logic options available)
- Digitally-Controlled Soft Start
- High Reliability (963 FITS/1,038,000 Hours MTBF)
- UL, TUV and CE Recognitions pending

DC-TO-DC CONVERTERS

Series QED

PHYSICAL DIMENSIONS

- NOTES
 1. DIMENSIONS SHOWN IN INCHES AND (MM)
 2. TOLERANCE ± 0.01 (± 0.25) UNLESS OTHERWISE SPECIFIED

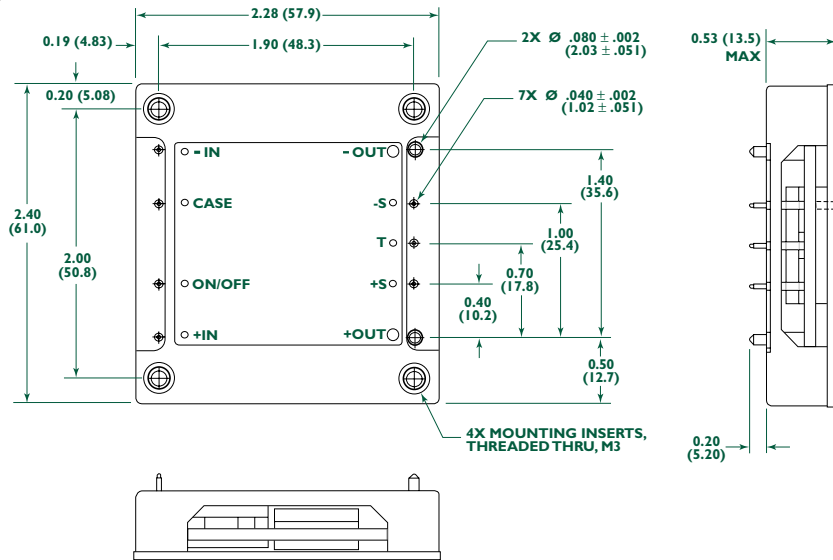

PIN FUNCTIONS

<p>-IN Input supply negative (return)</p> <p>CASE Case Ground is internally connected to the base-plate, and may be tied to -In, -Out or Earth ground, in order to reduce radiated emissions.</p> <p>ON/OFF Digital input, enables or disables the output of the converter. This signal is referenced to -IN, and is pulled up to +9 VDC through a 10 Kohm resistor.</p> <p>P (OPTION) — An open or high (>3.5 VDC) will enable the converter. A low (<1.0 VDC) will inhibit the converter.</p> <p>N (STANDARD) — A low (<1.0 VDC) will enable the converter. An open or high (>3.5 VDC) will inhibit the converter.</p> <p>+IN Input supply positive</p>	<p>-OUT Output voltage negative (return)</p> <p>-S Remote sense negative (return)</p> <p>T Trim. Used for adjusting the output voltage.</p> <p>+S Remote sense positive</p> <p>+OUT Output voltage positive</p>
---	--

TYPICAL APPLICATION

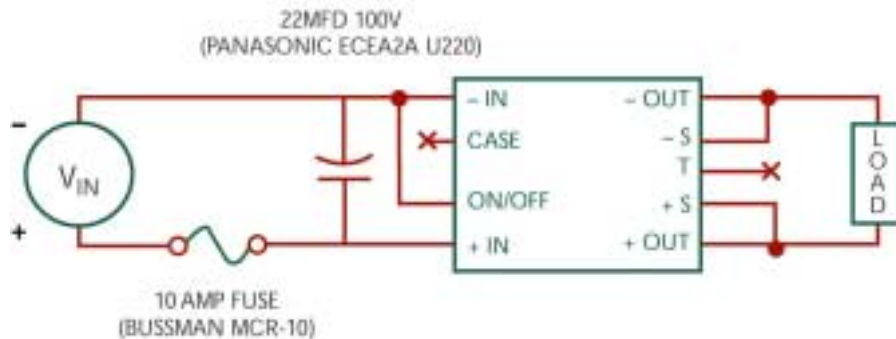

DC-TO-DC CONVERTERS

Series QED

ELECTRICAL CHARACTERISTICS - $V_{IN} = +48V$, $V_{OUT} = 5.0V$, Baseplate Temperature = 25°C, unless otherwise specified.

PARAMETER	MIN	TYP	MAX	UNITS	REMARKS
ABSOLUTE MAXIMUM RATINGS					
Input Voltage			100	VDC	
Input/Output/Baseplate Isolation Voltage			1,500	V	
Storage Temperature	-55		+125	°C	
Operating Temperature	-40		+85	°C	Temperature measured at the baseplate
ON/OFF Pin Voltage	-25		+25	VDC	
INPUT CHARACTERISTICS					
Operating Input Voltage Range	36	48	75	VDC	
Input Under/Voltage Lockout/Turn On	33.5	34.5	35.5	VDC	
Input Under/Voltage Lockout/Turn Off	30.5	31.5	33	VDC	
Input Over/Voltage Shutdown/Turn Off	77	78.5	79.5	VDC	
Input Over/Voltage Shutdown/Turn On	76	77	78	VDC	
No Load Input Current		70	80	mA	
Off Converter Input Current		1.5	3	mA	
Inrush Current Transient Rating		0.01		A ² s	
Input Reflected Ripple Current		35		mA	RMS
OUTPUT CHARACTERISTICS					
Output Voltage Set Point	4.95	5.00	5.05	VDC	
Output Voltage Load Regulation		±2	±10	mVDC	0A to 30A Output Load
Output Voltage Line Regulation		±2	±10	mVDC	36V to 75V Input Voltage
Output Voltage Regulation Over Temp.		±20	±60	mVDC	-40°C to +85°C Baseplate Temperature
Output Voltage Total Range	4.85		5.15	VDC	Any combination of load, line or temperature
Output Voltage Ripple and Noise		30	45	mV	Peak-to-Peak, 20 MHz bandwidth
		10	15	mV	RMS
Output Current Operating Range	0		30	ADC	
Output Current-Limit Inception	31	34	37	ADC	Output Voltage Sags by 10%
DYNAMIC CHARACTERISTICS					
Input Voltage Ripple Rejection		-60		dB	
Output Voltage Load Transient Response		200		mV Pk-Pk	50% to 75% of the Output Current
		200		µS	Settling Time to 1%
Turn-On Time		10	15	mS	
Turn-On Overshoot		3		%	10,000µF Capacitance, No Output Load
THERMAL CHARACTERISTICS					
Efficiency—100% Load	88	89		%	
Efficiency—80% Load	89	90		%	
Efficiency—60% Load	90	91		%	
Efficiency—40% Load	89	90		%	
Baseplate-to-Ambient Thermal Resistance	1.5		8.0	°C / Watt	
Board-to-Ambient Thermal Resistance		15		°C / Watt	
Thermal Shutdown		110		°C	Temperature measured at the baseplate
Thermal Shutdown Restart		100		°C	Automatic Recovery
ISOLATION CHARACTERISTICS					
Input/Output/Baseplate Isolation Voltage	1,500			VDC	
Input/Output Isolation Resistance	10			Mohm	
Input/Output Isolation Capacitance		3,300		pF	
CONTROL CHARACTERISTICS					
Switching Frequency	247	250	253	KHz	
ON/OFF Off-State Voltage (-P, Option)	0		1	VDC	
On-State Voltage	3.5		10	VDC	An open turns on the converter
ON/OFF Off-State Voltage (-N, Standard)	3.5		10	VDC	An open turns off the converter
On-State Voltage	0		1	VDC	
Output Voltage Trim Range	-20		+10	%	
Output Voltage Remote Sense Range			+10	%	
Output Over-Voltage Protection		125		%	Automatic Recovery

ORDERING INFORMATION

Example: ED**H1** — **48** — **050** — **P** — **00**

Outputs of 1.5, 2.0, 2.5, 3.3 and 5.0VDC are limited to 30A; 12.0VDC is 12.5A; 15.0VDC is 10.0A; 24.0VDC is 6.25A; and 28.0VDC is 5.4A.

PACKAGE SIZE	COMPONENTS	INPUT VOLTAGE	OUTPUT VOLTAGE	ON/OFF LOGIC	HEATSINK (fin ht. plus base)
H = Half Brick	1 = Board only	24 = (18V–36V)	015 = 1.5VDC	P = Positive Logic	00 = No heatsink
	2 = Board & Baseplate	48 = (36V–75V)	020 = 2.0VDC	N = Negative Logic	01 = 0.25 (6.35) H
	3 = Board, Baseplate & Cover		025 = 2.5VDC		02 = 0.40 (10.2) H
			033 = 3.3VDC		03 = 0.50 (12.7) H
			050 = 5.0VDC		04 = 0.60 (15.2) H
			120 = 12.0VDC		05 = 0.70 (17.8) H
			150 = 15.0VDC		06 = 0.90 (22.9) H
			240 = 24.0VDC		07 = 0.25 (6.35) V
			280 = 28.0VDC		08 = 0.40 (10.2) V
					09 = 0.50 (12.7) V
					10 = 0.60 (15.2) V
					11 = 0.70 (17.8) V
					12 = 0.90 (22.9) V

HEAT SINK DIMENSIONS

HORIZONTAL or VERTICAL HALF-BRICK

