

CONNECTING MULTIPLE CONVERTERS

Two or more DC-to-DC converters may be connected together to provide a higher output voltage, increased output current, fault tolerance, split power supplies and multiple output voltages. A PD150 series converter produces a single, fixed output voltage, with a power rating of up to 150 watts. This *Power Page*™ describes how to connect multiple PD150 series DC-to-DC converters to make a complete power supply system.

Please note that methods described in this *Power Page*™ are applicable to PD150 series DC-to-DC converters supplied by Powercube. They may, or may not, be suitable for converters

manufactured by other vendors. The vendor should always be contacted to insure that a particular connection will not cause any damage, or degrade the performance of your system. PD150 series converters are designed to be connected in series or parallel configuration without the need for additional components, or sacrifice of any performance characteristics.

Although most of the text in this *Power Page*™ refers to PD150 converters, the discussion is equally suitable for Model PD300, a 300 watt DC-to-DC converter. Where applicable, the differences are highlighted in the application.

Parallel Connection For Higher Output Power

For applications requiring higher output power, two or more (up to 20) PD150 converters with the same output voltage can be easily paralleled. Powercube's topology allows for this power boosting, without the need for additional components or separate booster, driver or master modules. The standard PD150 module is all that is required – thereby eliminating the need for stocking different types of modules. Also, no performance parameters are degraded.

Most manufacturers discourage connecting converters in parallel due to (i) degrading of performance, (ii) additional components requirement, (iii) unequal load sharing (even to the extent of 100% by higher output voltage unit).

Powercube converters perform normally when

connected in parallel. All modules share current to within 5% (typical) of the average load current, as long as all "SD" pins are connected to each other. PD150 series modules are factory adjusted to provide a specified output voltage within an accuracy of 1%. When connected in parallel, no further trimming or adjustment is required.

Figure 1 shows the connection for multiple modules connected in parallel. As shown, the input of each module should be fused to prevent a failed unit from shorting the input bus. "SD" pins should be connected to each other in order, to ensure accurate power sharing. The "SYNC" pins of each paralleled module should be connected together. By connecting the "SYNC" pins, the switching frequency of the modules will be synchronized to the module with the highest switching frequency. Although the modules will



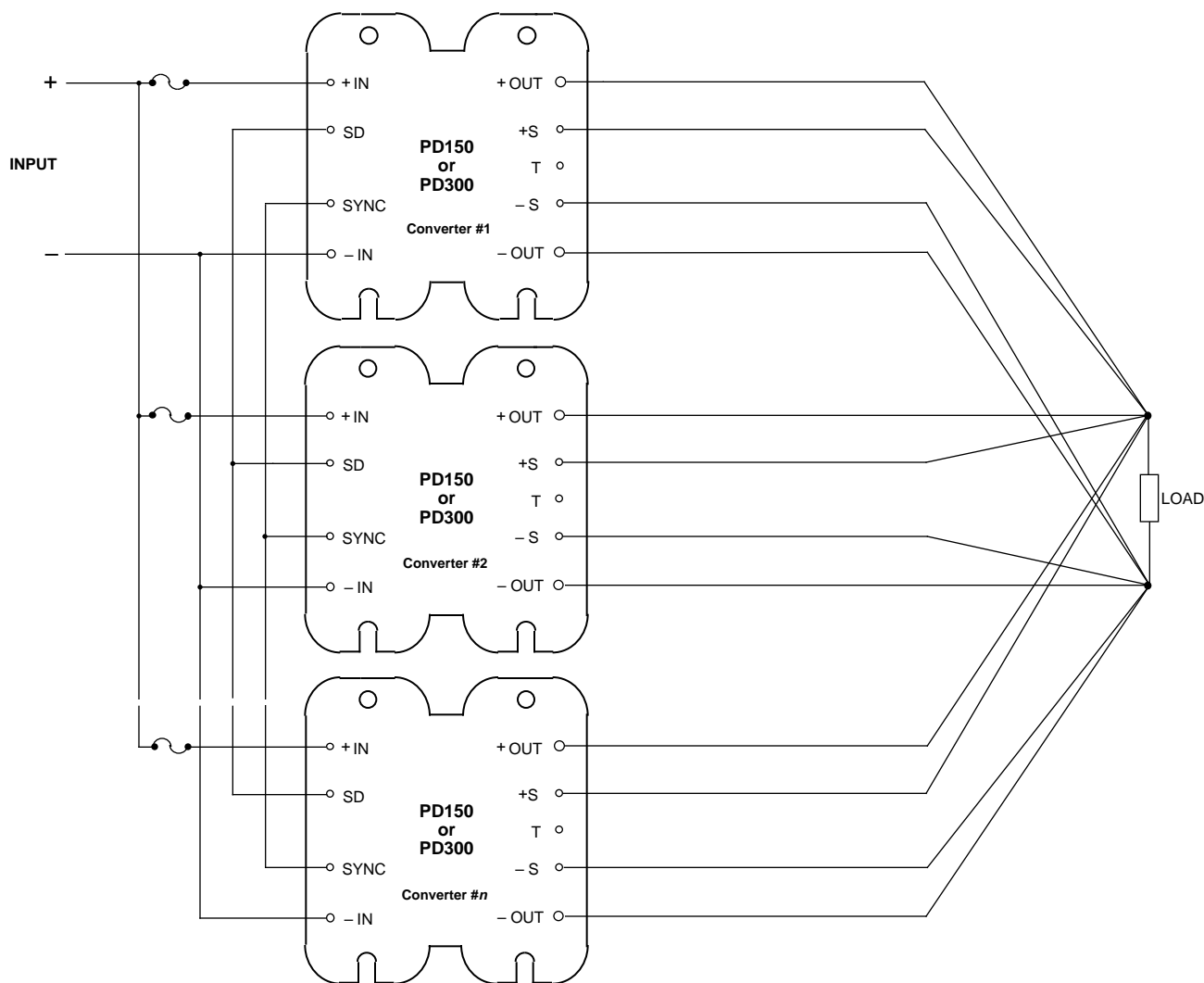

Figure 1. Connecting Modules in Parallel

operate in parallel without the “SYNC” pins connected, substantially greater noise and ripple will be generated.

It is interesting to note that when the “SYNC” pins are not connected to each other the ripple output of the system does not degrade as the number of modules connected in parallel increases. This is due to cancellation of random beat frequencies and the output ripple is similar to having the “SYNC” pins connected.

The output leads from all modules must be as short as possible. All sense leads, “+S” and “-S” pins of the paralleled modules, should be connected to common points as close to the load as possible to obtain the most accurate power sharing and output voltage regulation.

The **output voltage** of the paralleled system using PD150 converters is determined by the module with

the lowest output voltage, which becomes the master, and all other paralleled modules will match its output voltage. Factory set output voltage is sufficient to provide an output which is within 1% of specified voltage. If your system requires trimming of the output voltage of the paralleled modules, trim each converter individually as described in *Power Page PP42*.

The **output power (or current)** is the sum of all modules connected in parallel. Irrespective of the load, PD150 series converters share it equally within 5% (typical) of each other, as long as "SD" pins are connected to each other. Output **noise and ripple** is the same as that of one PD150 module as long as "SYNC" pins are connected to each other.

As with any power supply system, good fundamental engineering practices must be followed when applying multiple converters. *Power Page PP41* recommends connections and components to help you achieve optimum performance from your system. For paralleled modules, adequate bussing of both input and output power leads is necessary to ensure accurate power sharing. If you are mounting the modules on a printed circuit board, run wide traces, particularly for connecting "-IN", "-OUT", and "+OUT" connections. Also, protect the "SD" and "SYNC" connections from noise. Ideally these connections will be traces on a printed circuit board which are located as closely as possible to a wide "-IN" connecting trace. Each module must have adequate heat sinking to dissipate the heat resulting from full-load operation.

Connecting Converters for Fault Tolerance

For critical applications where a power supply failure cannot be tolerated, it is important to design a power supply system that is fault tolerant, in that a single failure does not cause a power shut down. A cost effective way to provide a very high level of reliability is an "N + 1" redundant system. The basic idea of fault tolerance through redundancy is to design a system so that there is at least one more module than the minimum required to carry the load. For example, if the load requirement is 85 amperes at 5 volts, a fault tolerant redundant system will use five (5) PD150 converters, each capable of delivering 23 amperes of current. Essentially four converters deliver the load and one is redundant, therefore the name "N + 1" redundant system.

An "N + 1" redundant system uses parallel connected converters configured in a way such that a failure of any one module will not affect the power

system's ability to deliver full power. Figure 2 shows a recommended way to connect converter modules for an "N + 1" redundant system. All possible failures of a converter module, such as an input or output short circuit or zero output on one module, are accounted for with this system configuration. The OR-ing diodes permit one converter to fail without affecting the others, which continue to power the load.

The diodes must be selected with a Peak Inverse Voltage rating of greater than the load voltage and a forward current rating of greater than the full load current. Depending on the voltage drop, these diodes may dissipate high power. Therefore, adequate heat sinking must be provided. The OR-ing diodes should be low forward voltage drop Schottky diodes to avoid excessive forward voltage

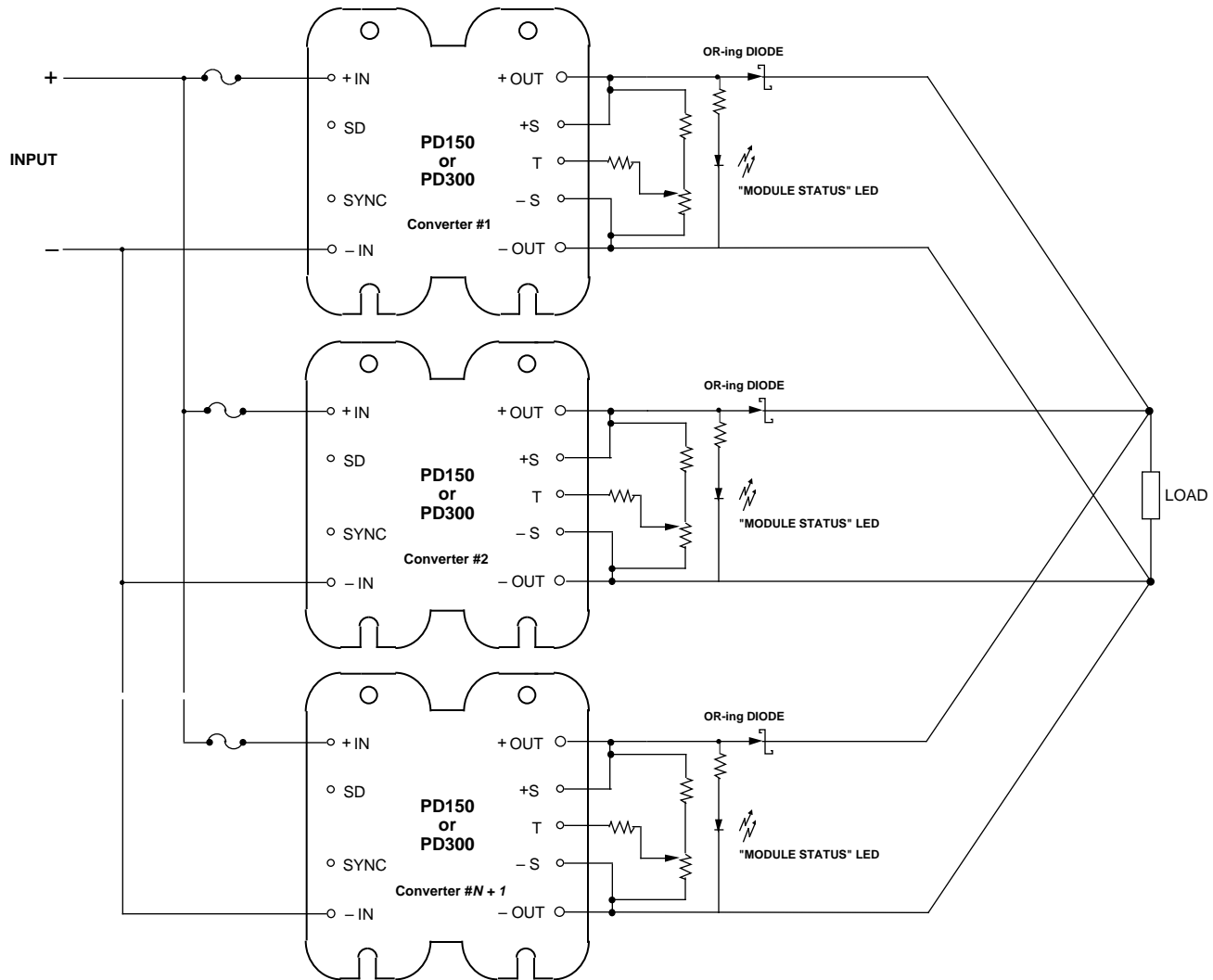

Figure 2. N + 1 Redundant System

drops. This is especially important if the output voltage is 5V or less. International Rectifier manufactures several OR-ing Schottky diodes, including the 85CNQ015, which at room temperature has a 0.3V forward drop at 20A.

Each module's positive input should be individually fused. *Power Page™ PP41* lists the proper fuses for different input voltages.

If your application requires "N + 1" redundancy, it is recommended that you specify higher (by a diode drop of OR-ing diode) output voltage than the desired load voltage to compensate for the additional diode drop.

The **output voltage** of the "N + 1" redundant system, as expected, is determined by the module with the highest output voltage which also

supplies more current than the other modules. Note that this is different from a paralleled system (when "SD" pins are connected to each other) where the module with the lowest voltage is the master and load is shared equally. This is because of how the internal feedback loop is mechanized in the PD150 design.

Ripple and noise at the output of an "N + 1" redundant system is almost the same as that of one PD150 converter. Since "SD" pins are not connected to each other (to keep modules isolated from each other), the current sharing accuracy is reduced to 30%. Although not very important, please note that converters from other vendors may have one module supplying all or most of the current. The reason that current sharing is not important in a redundant system is that each converter must be capable of providing full-load current. Also, for the same reason, each converter must have sufficient heat sinking to handle the maximum power dissipation.

Although Gate Out signal, with an optocoupler, can be used for determining module status, Powercube does not recommend this approach as it is able to detect failure in only 70% of the circuit. A superior method which checks almost 100% of the circuitry of DC-to-DC converters is to monitor the output by using "module status" indicator LED. Circuits like this are useful in verifying that all modules are functioning, since one converter module can fail without system malfunction. Any circuit which senses and evaluates the voltage directly at the output of the converters will be suitable for determining the health of the "N + 1" redundant system.

Although the paralleling, remote sense and

synchronizing functions could be used to improve the load sharing, load regulation and ripple and noise, the chances of a single module failure causing a power system failure increases. For example, if the "SD" pins of all modules in the array were connected together (to improve load sharing between modules), and one converter were to fail such that the "SD" pin were shorted to input ground, *all* modules would shut down and the entire system would fail. Minimize the connections between converter modules within the "N + 1" redundant system, and be careful to isolate (using diodes, fuses, etc.) the necessary connections.

Some performance parameters (such as regulation) will be degraded due to the forward voltage drop across the diodes. Voltage regulation is the measure of how well a constant DC voltage is maintained at the load. Voltage regulation in the circuit of figure 2 may not be sufficient for some applications. Variations in the forward drops of the OR-ing Schottky diodes with changing temperatures and currents, and resistance between the power modules and the load, cause voltage regulation to degrade. The voltage at the load may vary by as much as 5%, especially for low voltage, high current loads.

The circuit shown in figure 3 improves the voltage regulation at the load by connecting the Sense pins to the load. Note that a resistor in series between the +Sense pins and the load is necessary to isolate a failed power module from affecting the load, as well as improving current sharing between modules. When determining the values for the resistor, be aware that a resistor is present between the "+S" and the "+OUT" pins internal to the PD150 module. This resistor is 20 Ω for all output voltage modules

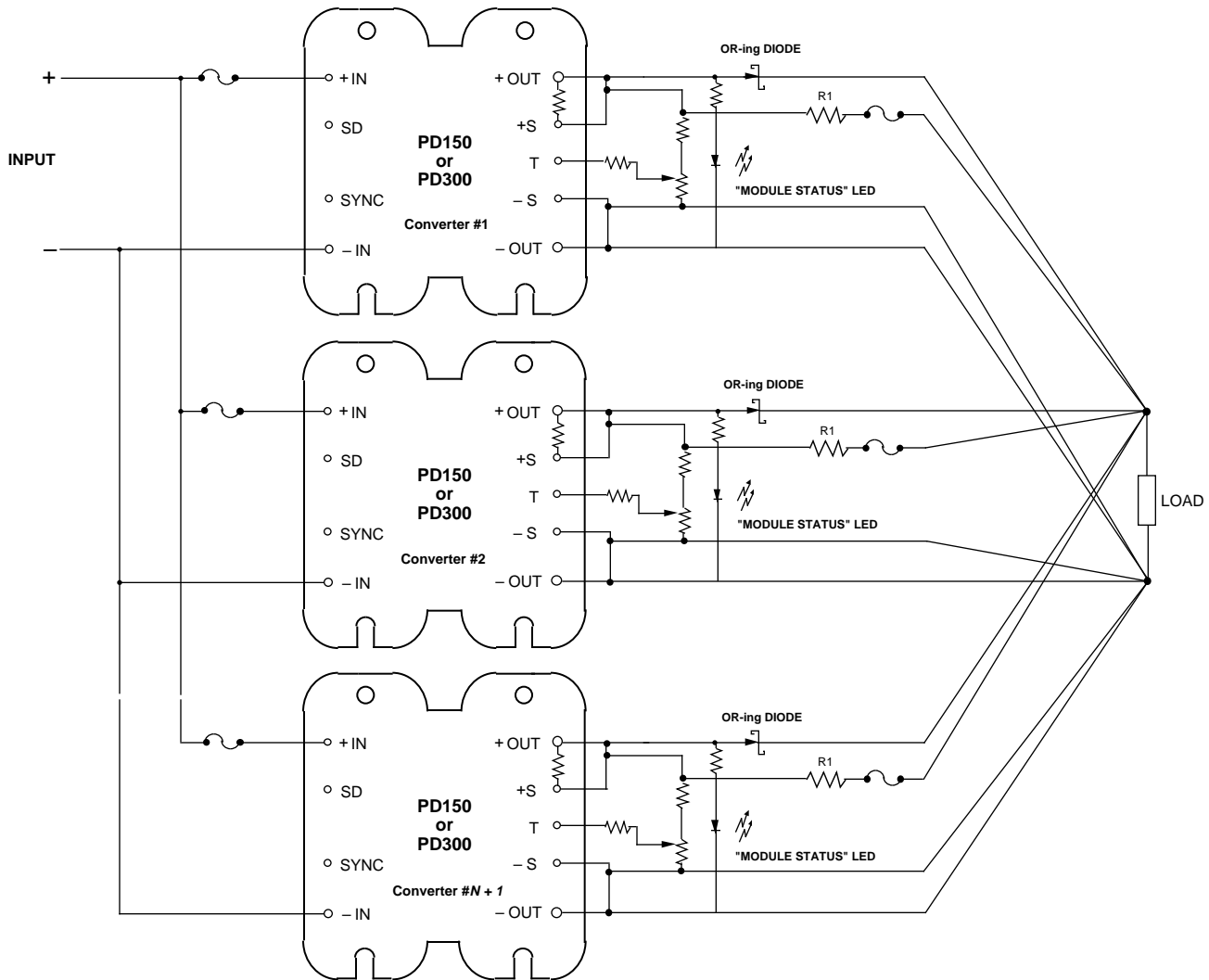

Figure 3. N + 1 Redundant System with Improved Voltage Regulation

except the 28V output modules, and 200 for the 28V output modules. The recommended value for the series resistor R1 is 100 ohms for 28V output modules and 10 ohms for all other output modules. Note that if a converter fails and output goes to zero (or if "+OUT" pin of a converter is shorted to ground), the R1 will burn out. This is because full load voltage from other modules is applied across R1 of the failed module. In order to prevent that (for

safety reasons), the user should insert a fuse in series with R1 as shown in Figure 3. Littlefuse® makes PICO II series very fast-acting 1/8 ampere fuses (leaded) and PICO SMD series very fast-acting 1/8 ampere fuses (surface mount).

In both schemes of figure 2 and figure 3, the output voltage on the output of each converter should be trimmed (see *Power Page™ PP42* for more details

on output voltage trimming) to within 0.25% of each other, so that all modules in the array share the load. Connections from the module output through the OR-ing diode to the load should be identical for each module in the array, since this determines how well the modules share the load. Also, there should be a sufficient heat sinking on each module so that each converter can handle the increased load (if another module fails), or its full rated power, whichever is less.

If more than one redundant converter is used (for higher reliability) the system is referred to as an "N + X" redundant power supply system. Since PD150 converters connected in parallel are all identical (as compared to master/slave or driver/booster), they are ideally suited for "N + 1" or

"N + X" redundancy.

If a power supply system design requires replacing bad modules without shutting down the system, then an additional feature called "Hot Swap" capability is required. This consists of a certain mechanical arrangement that allows converters to be removed and inserted without upsetting the output. The failed converter, as determined by LED status, is removed and a new converter is inserted without interrupting the power supply system.

Since "SD" and "SYNC" functions are not utilized for "N + 1" redundant system, all discussions and circuits are equally applicable to both pin out option "P" and option "V" of the PD150 converters.

Connecting Converters for Multiple Output Voltages

Often power systems require more than one output voltage. Figure 4 shows an example of a three output power system using PD150 modules. Since each module has its input and output isolated from each other, a module can be hooked up to deliver either positive or negative polarity. In the example, both positive and negative 12 volt outputs are generated from identical PD150-300-12P modules. The +5V is created by using a PD150-300-05P.

Note that in this example the +5V return is isolated from the $\pm 12V$ return. Many times it is a good idea to maintain separate grounds for the +5V logic ground, which often has noise from the down-stream

digital processing system, and the $\pm 12V$ analog ground, which is usually sensitive to digital "spiky" type noise. If the digital and analog grounds must be tied together, they should be tied at a single point. Usually the best point for the grounds to be tied is back at the outputs of the PD150 modules. However, ground separation should be maintained throughout the remainder of the system.

As discussed earlier, each module's input should be fused, and the "SYNC" pins connected. The power system will deliver the correct voltages without the "SYNC" pins connected. However ripple and noise will be increased. Adequate bussing of both the input and output power leads is required, and the

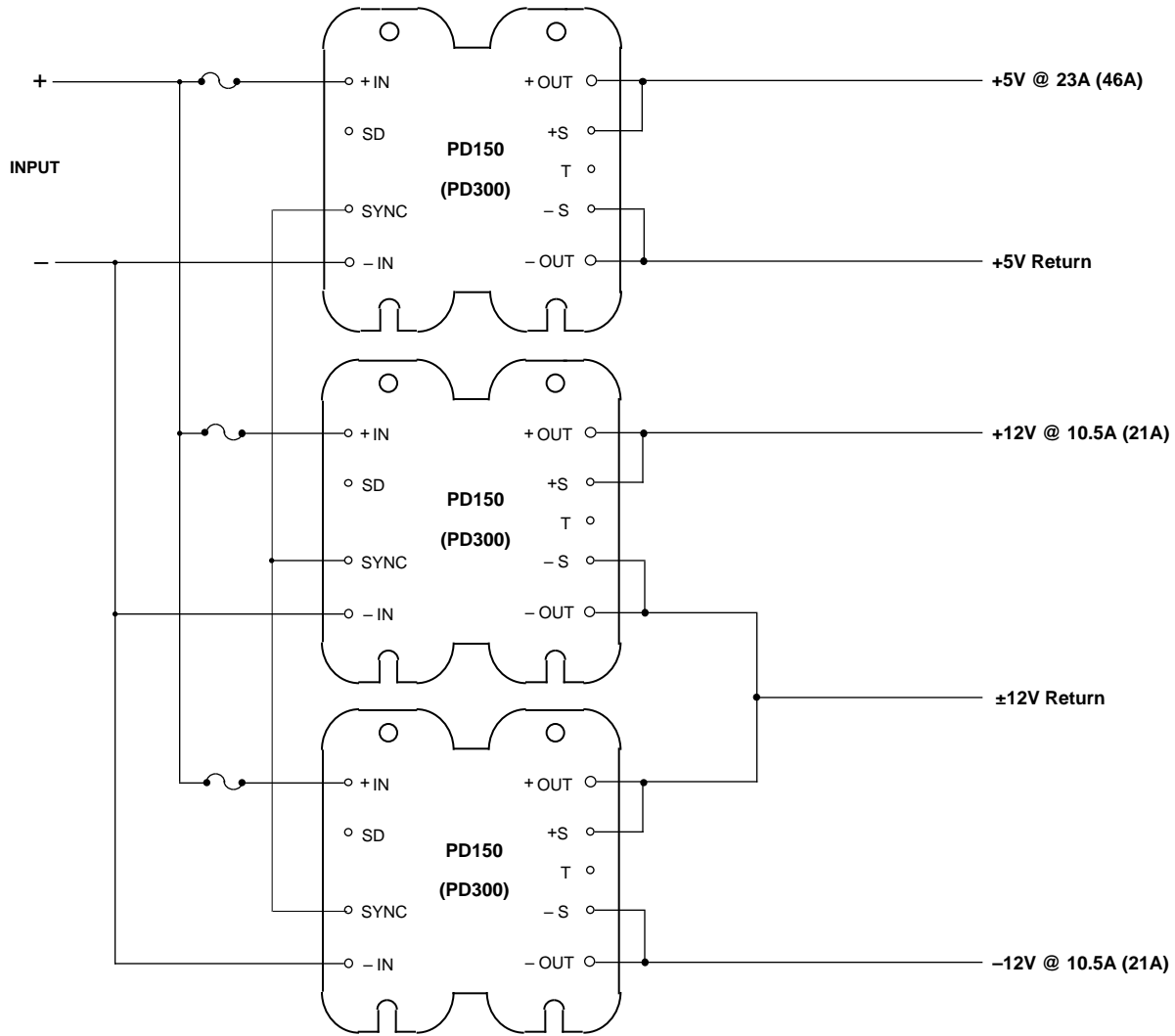

Figure 4. Multiple Output Voltage Power System

“SYNC” connections should be protected from noise.

Tracking split power supply: Figure 5 shows a method for creating a split supply with adjustable, tracking output voltages. Output voltage of PD150 module #2 is trimmed using methods described in

Power Page PP42. A simple circuit using two NPN transistors (2N2222 or equivalent) and two 10K resistors is used to make sure the voltage output of module #1 tracks the output voltage of module #2. Essentially, the trim point of module #1 is being controlled by the trim point of module #2, thereby creating a tracking output voltage.

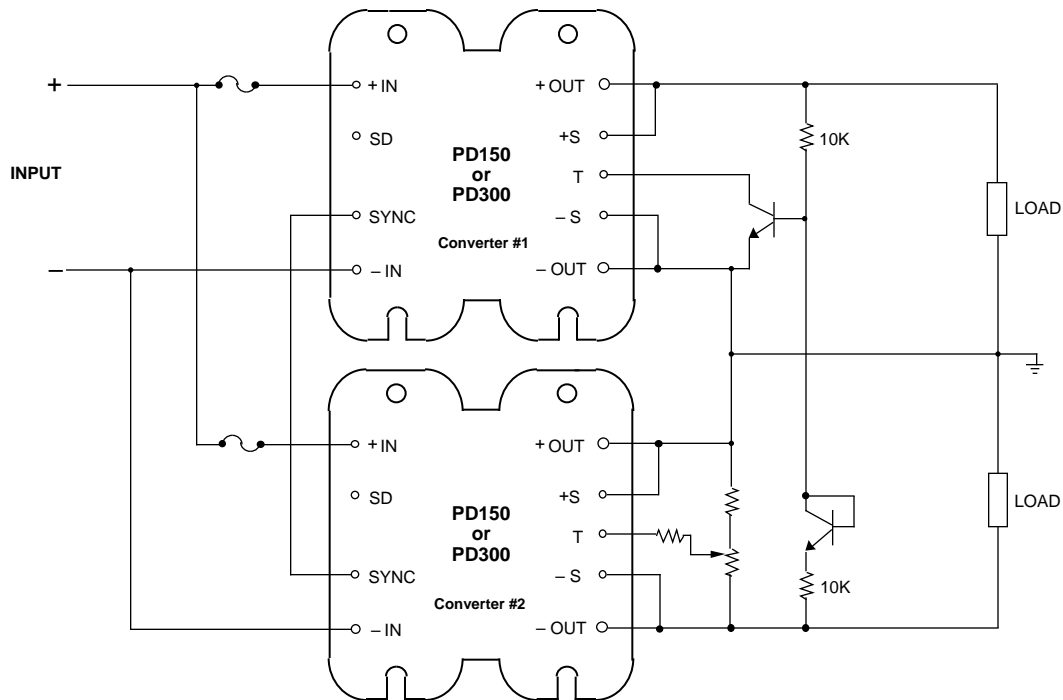

Figure 5. Adjustable Tracking Split Supply

Connecting Converters in Series for Higher Output Voltage

Converter outputs are connected in series to obtain higher output voltage. In general, most DC-to-DC converters can be operated with outputs connected in series. Nevertheless, it is advisable to check with the vendor to understand the limitations of their converters. For some vendors, output of one converter could affect the control circuit of another converter. Model PD150 DC-to-DC modules may be connected in series without affecting the internal operation of any of the converters. Figure 6 shows the correct connection method. Reverse biased diodes D1 and D2 across the output of each series-connected converter protect one module from the reverse voltage of the other output in the event that the output load is shorted. They also

prevent the module output from going negative if they turn off prior to the remaining modules in the series array. These diodes require a minimum reverse voltage rating of the individual module output voltage. Recommended peak inverse voltage (PIV) rating is equal to at least twice the module voltage and a minimum forward current (I_F) rating equal to the output current.

Diode D3 provides protection against load capacitance back-feeding into the converter (and possibly damaging it) during turn-off. Diode D3 should have at least twice the total output voltage and a minimum forward current rating of the output current.



As shown in figure 6, the **output voltage** across the load is the sum of the output voltages of all the modules connected in series. The total output

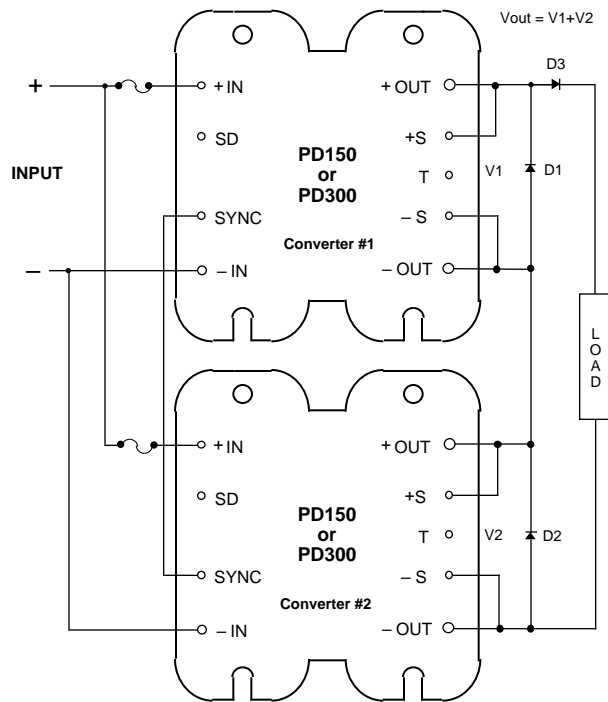

Figure 6. Series connection for Higher Output Voltage

voltage using this technique is limited to 1000VDC. **Output current** is determined and limited by the converter supplying the lowest current. As long as converters are synchronized (“SYNC” pins connected to each other) the output **ripple and noise** will be the sum of the ripple and noise of all the modules. Although series power systems will work without “SYNC” pins being connected, the ripple frequency and amplitude will be unpredictable. Predictability of output ripple is required in many noise sensitive systems. Examples of such systems are RF transmitter, RF receivers, low noise amplifiers and data acquisition systems.

As discussed earlier, each module’s input should be fused. Adequate bussing of both the input and output power leads is required and the “SYNC” connection should be protected from noise.

*Also note that modules should **NEVER** be connected in series – opposing (voltage subtracting) configuration, since they cannot sink sufficient current to operate safely in that configuration.*

Multiple Converter ON / OFF Control

If an application requires several modules to be turned ON and OFF at the same time, “SD” pins are connected together so that a single controlling component will shut off all connected modules at the same time. Figure 7 shows a multiple output voltage power system being controlled by a single switch SWI. Diodes D1, D2 and D3 provide isolation and also prevent multiple failures if the “SD” pin is

accidentally shorted to a high voltage (e.g., “+IN”). These diodes are small signal diodes 1N4148 (or equivalent) for input voltages of less than 75 volts. For modules with input voltages greater than 75 volts, 1N4006 diodes (or equivalent) should be used. SWI is a mechanical or a solid state switch that is used to disable all converter modules. If a logic disable is used, the voltage of the “SD” pin

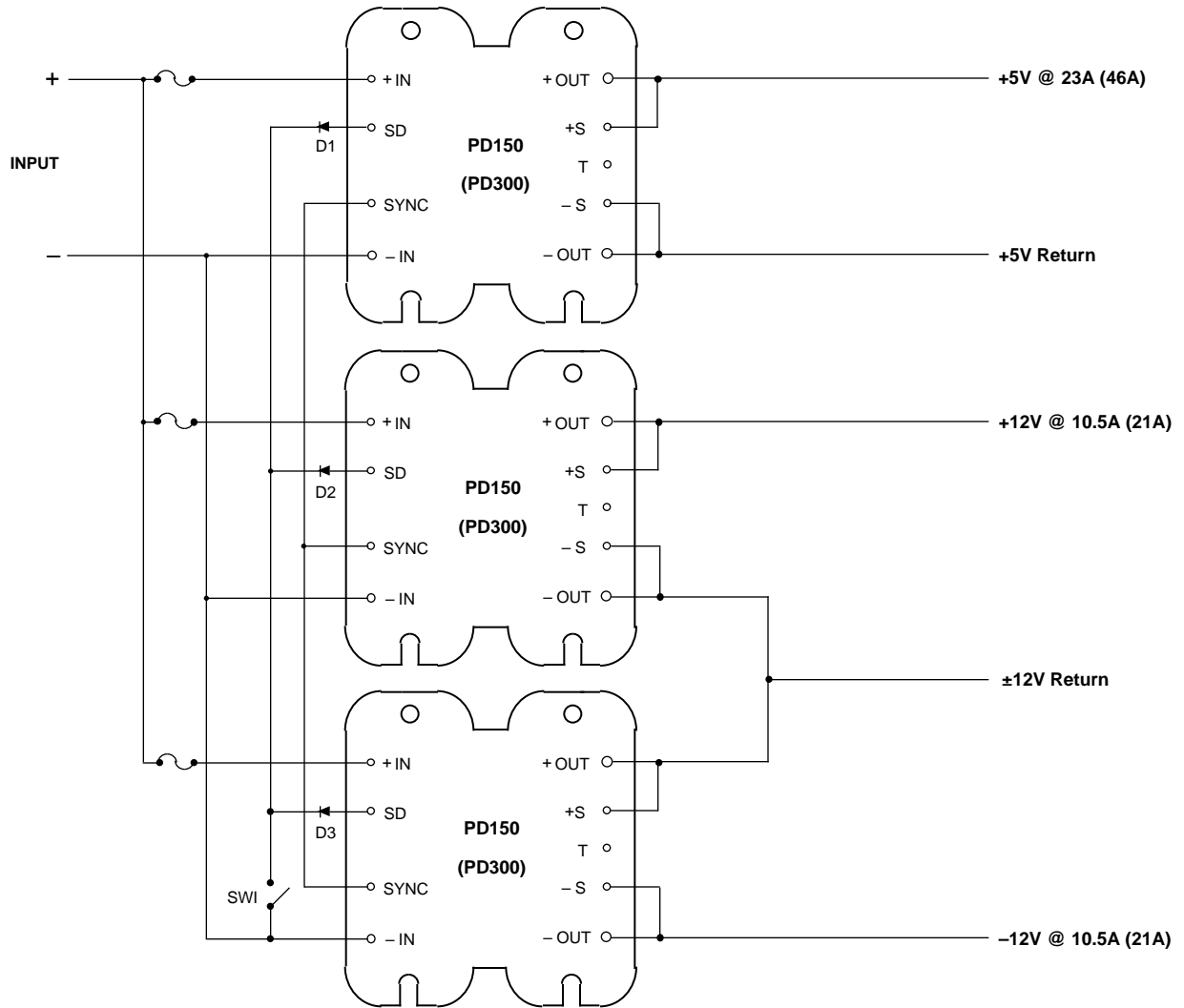

Figure 7. ON / OFF Control for Multiple Converter

must be less than 1 volt for the module to be turned OFF. The open circuit voltage of the "SD" pin is less than 25VDC, and the required sink current is less than 4mA. Please note that the "SD" pin is referenced to the "-IN" pin. If the turn-off signal is

referenced to a different return, an opto-isolator or relay should be used to isolate the control ground from "-IN". For pin-out option "V", the "GATE IN" pin performs exactly the same function as the "SD" pin with regard to the ON / OFF control.

Switching Frequency Synchronization

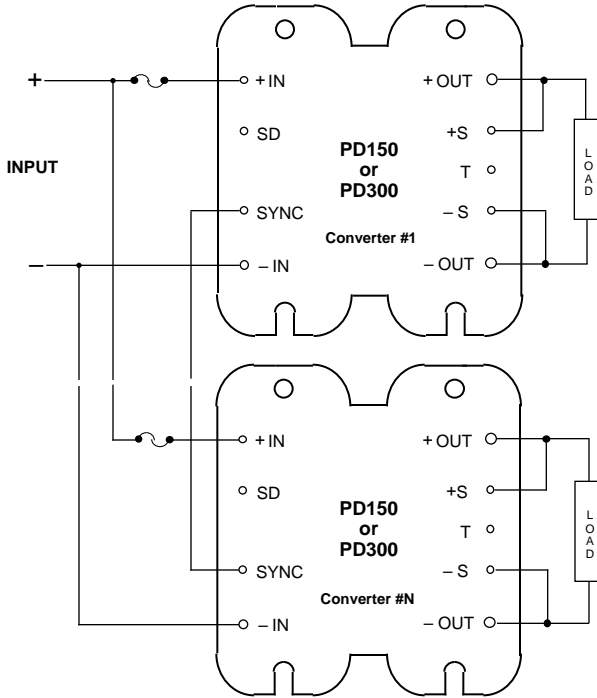

Figure 8. Synchronizing Modules

Synchronizing Between Modules: In order to prevent unpredictable system performance due to “beat frequencies,” it is often advisable to synchronize the converters so that they switch at the same switching frequency. To do this, simply connect the “SYNC” pins of the modules together as shown in figure 8. The converter with the highest switching frequency will become the master, and all other modules will “sync up” to the master. Up to 20 converters, with any combination of input and output voltages, can be synchronized in this manner. Remember that the converters to be “synched” must share a common “-IN”, and the “-IN” traces running between converters should be substantial enough to minimize noise.

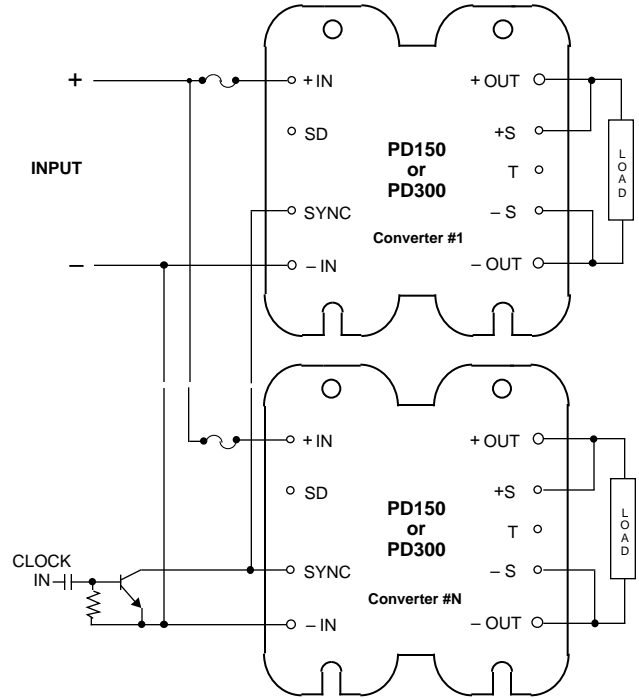

Figure 9. Synchronizing to an External Clock

Synchronizing to an External Clock: To synchronize the converter’s switching frequency to an external clock, connect the open collector transistor circuit to the “SYNC” pin as shown in figure 9. The “SYNC” function is negative-edge triggered, so the voltage must be allowed to recover to the full, un-triggered voltage prior to the next clock pulse. Select the master clock frequency to be below 425 KHz but above the maximum expected self-oscillating frequency of the converter. An external frequency of between 400 to 425 KHz is optimum, and will produce consistent results with all temperature and unit variations. Note that the “SYNC” pin is referenced to “-IN”, so an opto-isolator may be required if the clock signal is referenced to a different return.

Powercube makes no representation that use of its modules in the circuits described herein, or use of other technical information contained herein will not infringe on existing or future patent rights nor do the descriptions contained herein imply the granting of license to make, use, or sell equipment constructed in accordance therewith.